

Model No: COSMIC-1WYGB-1

Features:

- High-Power LED Type
- Size (mm): Φ 5.6*6.5 concave
- Emitting Color: Yellow
- RoHS
- Compliant



005



Model No.: COSMIC-1WYGB-1

■ Mechanical Dimensions

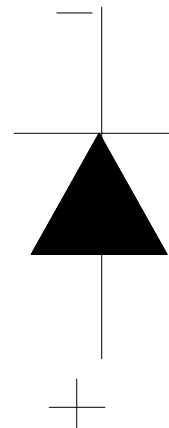
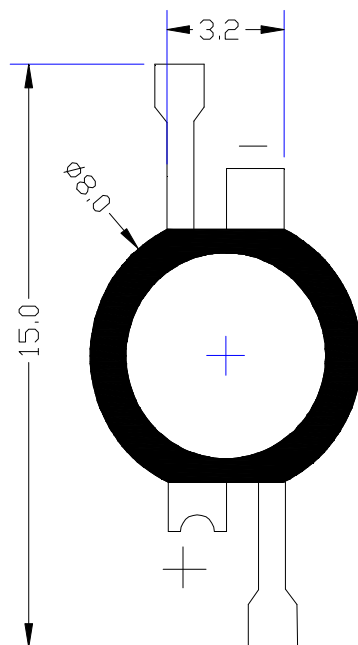
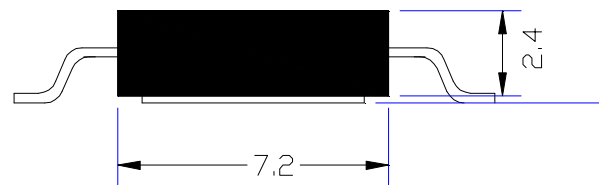
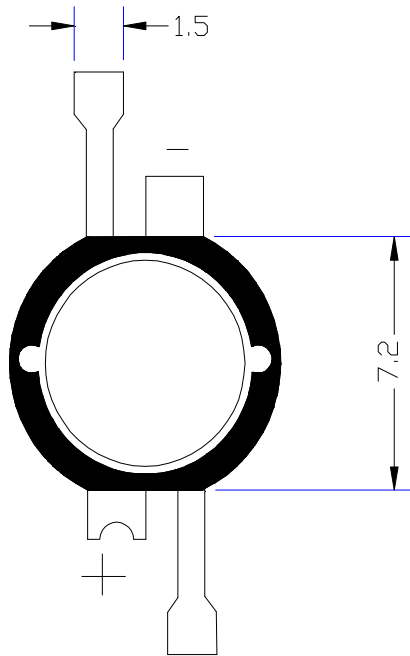

Notes:

1. Dimension in millimeter, tolerance is ± 0.2 mm.

3. The specifications, characteristics and technical data described in the datasheet are subject to change without prior notice.

Model No.: COSMIC-1WYGB-1

■ Absolute Maximum Ratings(Ta=25° C)

Items	Symbol	Absolute maximum Rating	Unit
Forward Current(DC)	IF	350	mA
Peak Forward Current*	IFP	500	mA
Power Dissipation	PD	1000	Mw
Operation Temperature	Topr	-40° C+85° C	°C
Storage Temperature	Tstg	-40°C+100°C	°C
Reverse Voltage	VR	5	V

*Pulse width \leq 1msec duty \leq 1/10

■ Typical Electrical & Optical Characteristics(Ta=25°C)

Items	Symbol	Condition	Min.	Typ.	Max	Unit
Forward Voltage	VF	IF = 350mA	2.30	---	2.60	V
Reverse Current	IR	VR = 5V			5	uA
Dominant Wavelength	λ (D)	IF = 350mA	592	---	595	nm
Luminous Flux	Φ_V	IF = 350mA	---	55	---	LM
50% Power Angle	2 $\theta_{1/2}$	IF = 350mA	---	120	---	Deg

■ Material

Item	Reflector	Wire	Encapsulate	Chip
Material	PPA	Gold	Silicone	AlGaInP

Note:

- 1.Luminous Intensity is based on the Foryard standards.
- 2.Pay attention about static for InGaN

Model No.: COSMIC-1WYGB-1

Typical Eletrical/Optical Characteristics Curves(Ta=25° C Unless Otherwise Noted)

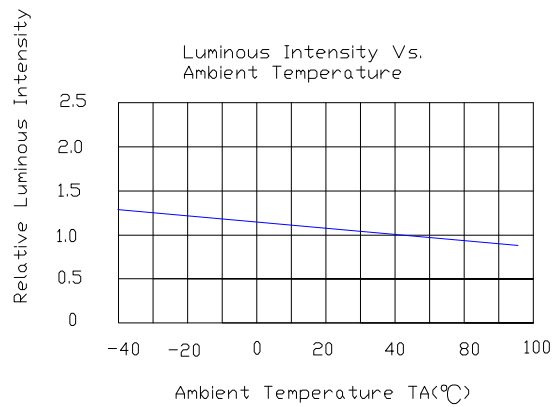
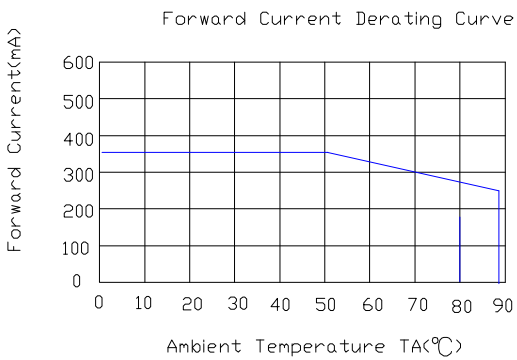
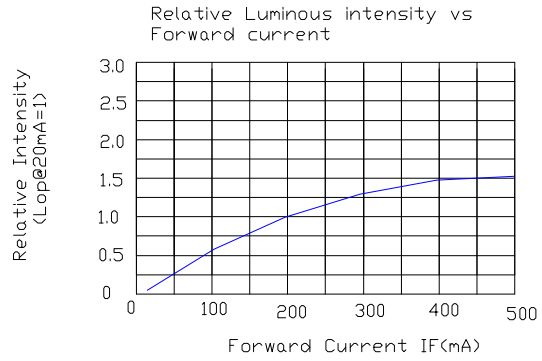
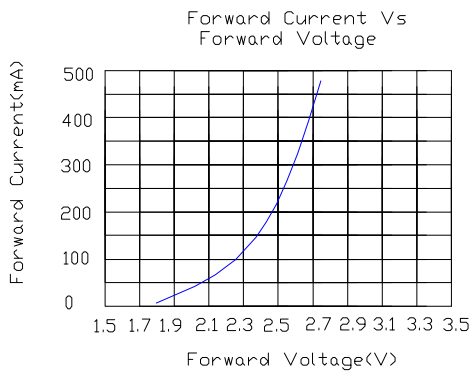
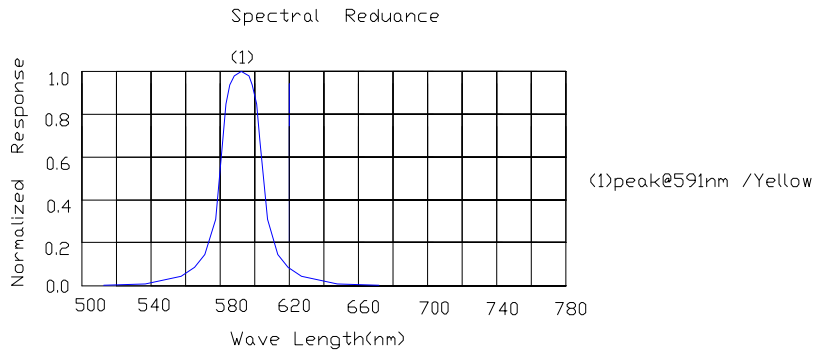

Radiation pattern.

