

Outline Dimension

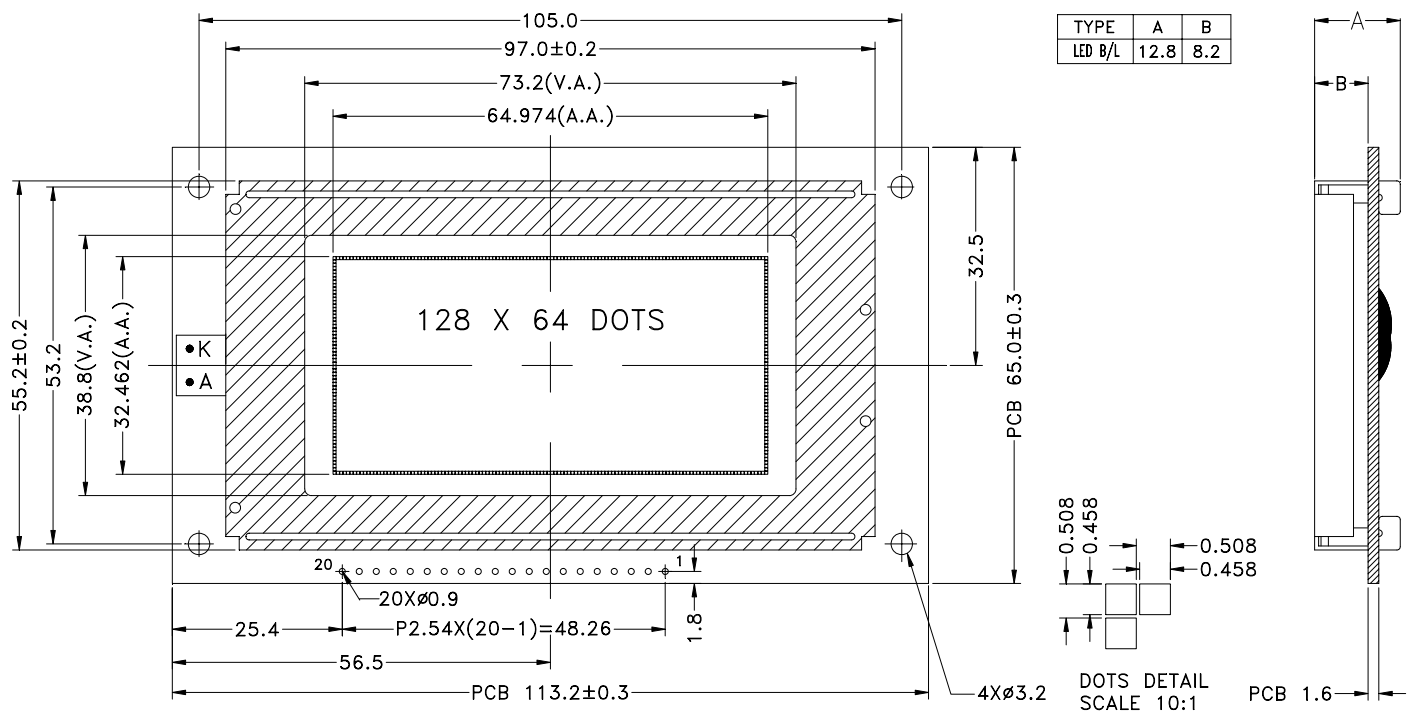

Graphic Type

Feature :

- 128x64 dot-matrix
- STN/Transflective/Positive/Y-G
- Backlight: Yellow-Green/Side Backlight
- Operating Temp.: -10°C ~ +60°C
- 1/64 duty cycle, 1/9 Bias
- Built-in Controller (SBN0064G or equivalent)
- Viewing angle: 6 o'clock

Absolute Maximum Rating :

Item	Symbol	Standard value			Unit
		M _{IN}	T _{YP}	M _{AX}	
Power supply for logic	V _{DD} -V _{SS}	-0.3	--	7.0	V
Input voltage	V _I	-0.3	--	V _{DD} +0.3	V

Adjusting Display Contrast :

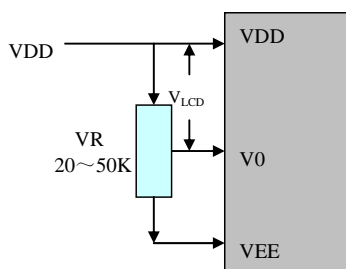

Note: Adjust V0 to VSS as an initial setting. When the module is operational, readjust V0 for optimal display appearance.

Electrical Characteristic : (V_{SS}=0V, T_a = 25°C)

Parameter	Symbol	Condition	M _{IN}	T _{YP}	M _{AX}	Unit
Supply voltage for logic	V _{DD}	--	4.8	5.0	5.2	V
Supply current for logic	I _{DD}	--	--	2.5	--	mA
Operating voltage for LCD	V _{LCD}	-10°C	--	--	--	V
		+25°C	--	13.0	--	V
		+60°C	--	--	--	V
Supply voltage for Backlight	V _{BL}	--	--	5.0	--	V
Supply current for Backlight	I _{BL}	--	--	210	--	mA

Interface Pin Connections :

Pin No.	Symbol	Level	Description
1	VSS	0V	Ground.
2	VDD	+5.0V	Supply voltage for logic operating.
3	V0	--	Adjusting voltage for LCD driving (variable).
4	D/I	H/L	In parallel bus mode register select 1: Data Register, 0: Instruction Register, Busy flag-Address Counter.
5	R/W	H/L	In parallel bus mode Read write control 0: write 1: read
6	E	H/L	In parallel bus mode Enable trigger
7-14	DB0-DB7	H/L	8-bit bi-directional data bus.
15	CS1	H/L	Chip Selection When CS1=1, Left area is Selection
16	CS2	H/L	Chip Selection When CS2=1, Right area is Selection
17	/RST	H/L	System reset low active
18	VEE	--	DC/DC voltage converter output.
19	A	+5.0V	Power supply for Backlight
20	K	0V	The backlight ground.